

HONDA

Power

Equipment

Owner's Manual

EM650

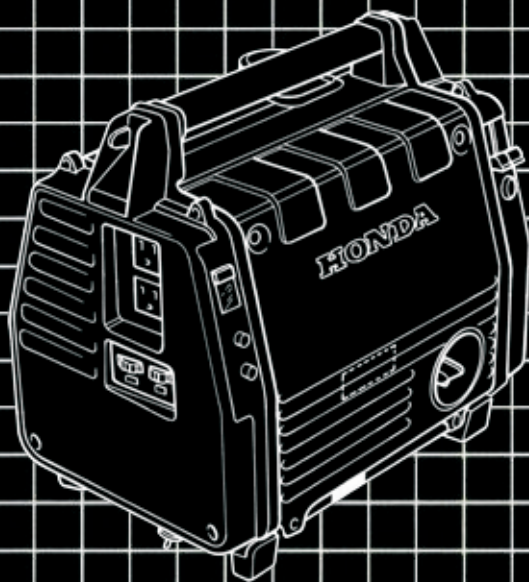

⚠ WARNING

The generator is a potential source of electrical shock if misused. Do not expose the generator to moisture, rain or snow. Do not let the generator get wet, and do not operate it with wet hands.



WARNING:



The engine exhaust from this product contains chemicals known to the State of California to cause cancer, birth defects or other reproductive harm.

Thank you for purchasing a Honda generator. We want to help you get the best results from your new generator and to operate it safely. This manual contains the information on how to do that; please read it carefully.

This owner's manual describes the operation and maintenance of the EM650 Honda generator. All information in this publication is based on the latest product information available at the time of printing. Honda Motor CO., Ltd. reserves the right to make changes at any time without notice and without incurring any obligation. No part of this publication may be reproduced without written permission.

This manual should be considered a permanent part of the generator and should remain with it if it is resold.

Safety Messages

Your safety and the safety of others is very important. We have provided important safety messages in this manual and on the generator. Please read these messages carefully.

A safety message alerts you to potential hazards that could hurt you or others. Each safety message is preceded by a safety alert symbol  and one of three words: DANGER, WARNING, or CAUTION.

These mean

 DANGER You WILL be KILLED or SERIOUSLY HURT if you don't follow instructions.

 WARNING You CAN be KILLED or SERIOUSLY HURT if you don't follow instructions.

 CAUTION You CAN be HURT if you don't follow instructions.

Each message tells you what the hazard is, what can happen, and what you can do to avoid or reduce injury.

Damage Prevention Messages

You will also see other important messages that are preceded by the word NOTICE.

This word means:

 NOTICE Your generator or other property could be damaged if you don't follow instructions.

The purpose of these messages is to help prevent damage to your generator, other property, or the environment.

CONTENTS

SAFETY	4
Safety Label Locations	4
Safety Information	6
COMPONENT IDENTIFICATION	8
CONTROLS	10
Engine Switch	10
Recoil Starter	10
Choke Lever	11
Pilot Lamp	11
Ground Terminal	12
Oil Alert System	13
AC Circuit Protector	13
DC Terminals	14
DC Circuit Protector	14
GENERATOR USE	15
AC Operation	16
DC Operation	17
Connecting the battery cables	17
Disconnecting the battery cables	18
High Altitude Operation	19
PRE-OPERATION CHECK	20
Engine Oil	20
Fuel Recommendation	21
STARTING/STOPPING THE ENGINE	24

MAINTENANCE	25
Maintenance Schedule	25
Engine Oil Change	26
Air Cleaner Service	27
Spark Plug Service	28
Spark Arrester Maintenance	31
TRANSPORTING/STORAGE	33
TROUBLESHOOTING	35
WIRNING DIAGRAM	37
SPECIFICATIONS	38
CUSTOMER SERVICE INFORMATION	39
INDEX	40

SAFETY

SAFETY LABEL LOCATIONS

These labels warn you of potential hazards that can cause serious injury. Read them carefully.

If a label comes off or becomes hard to read, contact your Honda Generator dealer for a replacement.

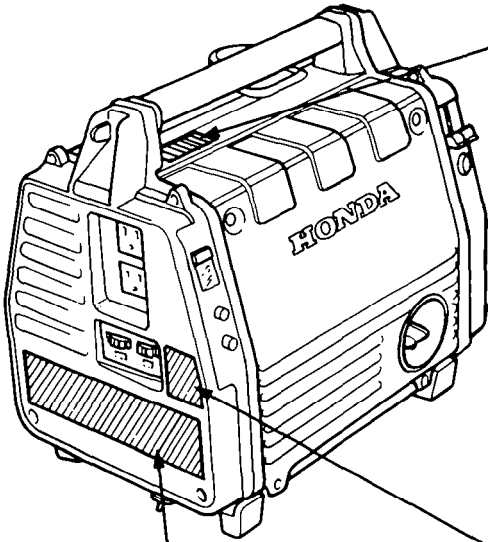

⚠ WARNING
ELECTROCUTION OR PROPERTY DAMAGE CAN OCCUR. DO NOT CONNECT THIS GENERATOR TO ANY BUILDING'S ELECTRICAL SYSTEM UNLESS AN ISOLATION SWITCH HAS BEEN INSTALLED BY A LICENSED ELECTRICIAN. READ OWNER'S MANUAL CAREFULLY.

DC
12V 8.3A

- BATTERY CHARGING ONLY.
- CHARGE DE BATTERIE SEULEMENT.
- ACUMULACION DE BATERIA SOLAMENTE.

HONDA EM650		HONDA MOTOR CO., LTD.		MADE IN JAPAN (A)			
AC	VOLTAGE 60Hz	120V RATED 550VA	MAX. 650VA	DC	VOLTAGE CURRENT	12V 8.3A	FUEL : GASOLINE (PETROL) COMBUSTIBLE : GASOLINA CARBURANT : ESSENCE
<p>WARNING</p> <p>DO NOT USE INDOORS. EXHAUST GAS CONTAINS POISONOUS CARBON MONOXIDE.</p> <p>CAUTION</p> <p>DO NOT CONNECT THE GENERATOR TO HOUSE WIRING. THIS CAN DAMAGE THE GENERATOR OR ELECTRICAL APPLIANCES.</p>		<p>ATTENTION</p> <p>NE PAS UTILISER DANS UN ENDRIT FERMÉ A CAUSE DU RISQUE D'EMPOISONNEMENT DU GAZ.</p> <p>POUR L'EXPLICATION DÉTAILLÉE, VOIR LE MANUEL D'UTILISATEUR.</p>		<p>ATENCIÓN</p> <p>NO LO USE EN LUGARES CERRADOS, COMO EL MONÓXIDO DE CARBONO ES VENENOSO.</p> <p>CONSULTE EL MANUAL PARA EL BUENO PARA LOS DETALLES SOBRE EL MANEJO.</p>			
<p>● WHEN USING DC OUTPUT, AC LOAD MUST NOT EXCEED 300VA AT 60Hz.</p> <p>● A L'EMPLOI D'UN COURANT CONTINU DE SORTIE, LA CONSOMMATION EN COURANT ALTERNATIF NE PEUT PAS DÉPASSER 300VA A UNE FREQUENCE DE 60Hz.</p> <p>● CUANDO SE UTILICE SALIDA DE CC, EL CONSUMO DE CA NO DEBERÁ SER SUPERIOR A 300VA CON 60Hz.</p>							

■ DO NOT FILL THE FUEL TANK BEYOND THE UPPER LIMIT LINE.
 ■ NE PAS FAIRE LE PLEIN AU DESSUS DU REPÈRE DE NIVEAU MAXIMUM.
 ■ NO ECHAR COMBUSTIBLE MAS DE LINEA DE NIVEL.

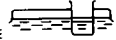

■ STOP THE ENGINE BEFORE REFUELING. CHECK FOR SPILLED FUEL OR FUEL LEAKS.
 ■ CONTRÔLER QU'IL N'Y A NI FUIITE NI ESSENCE RÉPANDUE SUR L'APPAREIL. AVANT DE REFAIRE LE PLEIN: ARRÊTER LE MOTEUR.
 ■ INSPECCIONAR PARA COMBUSTIBLE DERRAMADO O ESCAPE ANTES ECHAR COMBUSTIBLE: PARAR MOTOR ANTES DE ECHAR COMBUSTIBLE AL DEPOSITO.

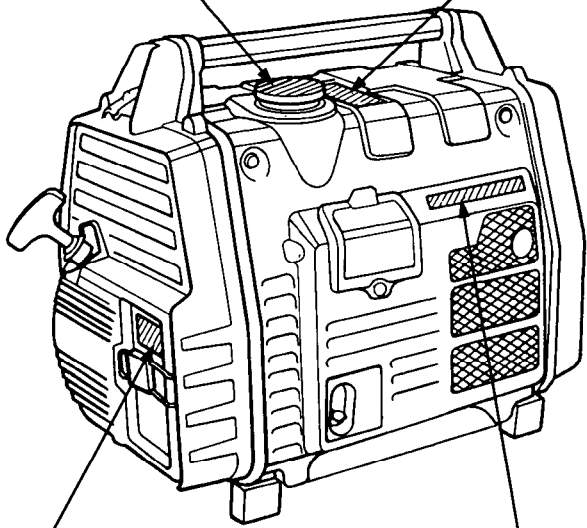

AIR CLEANER MAINTENANCE

■ CLEAN ELEMENT EVERY 50 HOURS (EVERY 10 HOURS UNDER DUSTY CONDITIONS). WASH IN HIGH FLASH-POINT SOLVENT, SQUEEZE DRY, THEN DIP IN CLEAN ENGINE OIL AND SQUEEZE OUT EXCESS OIL.

HOT · EXHAUST
ECHAPPEMENT · CHAUD



SAFETY INFORMATION

Honda generators are designed to give safe and dependable service if operated according to instructions. Read and understand this owner's manual before operating your generator. You can help prevent accidents by being familiar with your generator's controls, and by observing safe operating procedures.

Operator Responsibility

- Know how to stop the generator quickly in case of emergency.
- Understand the use of all generator controls, output receptacles, and connections.
- Be sure that anyone who operates the generator receives proper instruction. Do not let children operate the generator without parental supervision.

Carbon Monoxide Hazards

- Exhaust contains poisonous carbon monoxide, a colorless and odorless gas. Breathing exhaust can cause loss of consciousness and may lead to death.
- If you run the generator in an area that is confined, or even partially enclosed, the air you breathe could contain a dangerous amount of exhaust gas. To keep exhaust gas from building up, provide adequate ventilation.

Electric Shock Hazards

- The generator produces enough electric power to cause a serious shock or electrocution if misused.
- Using a generator or electrical appliance in wet conditions, such as rain or snow, or near a pool or sprinkler system, or when your hands are wet, could result in electrocution. Keep the generator dry.
- If the generator is stored outdoors, unprotected from the weather, check all electrical components on the control panel, before each use. Moisture or ice can cause a malfunction or short circuit in electrical components which could result in electrocution.
- Do not connect to a building's electrical system unless an isolation switch has been installed by a qualified electrician.

Fire and Burn Hazards

- The exhaust system gets hot enough to ignite some materials.
 - Keep the generator at least 1 meter (3 feet) away from buildings and other equipment during operation.
 - Do not enclose the generator in any structure.
 - Keep flammable materials away from the generator.
- The muffler becomes very hot during operation and remains hot for a while after stopping the engine. Be careful not to touch the muffler while it is hot. Let the engine cool before storing the generator indoors.
- Gasoline is extremely flammable and is explosive under certain conditions. Do not smoke or allow flames or sparks where the generator is refueled or where gasoline is stored. Refuel in a well-ventilated area with the engine stopped.
- Fuel vapors are extremely flammable and may ignite after the engine has started. Make sure that any spilled fuel has been wiped up before starting the generator.

COMPONENT IDENTIFICATION

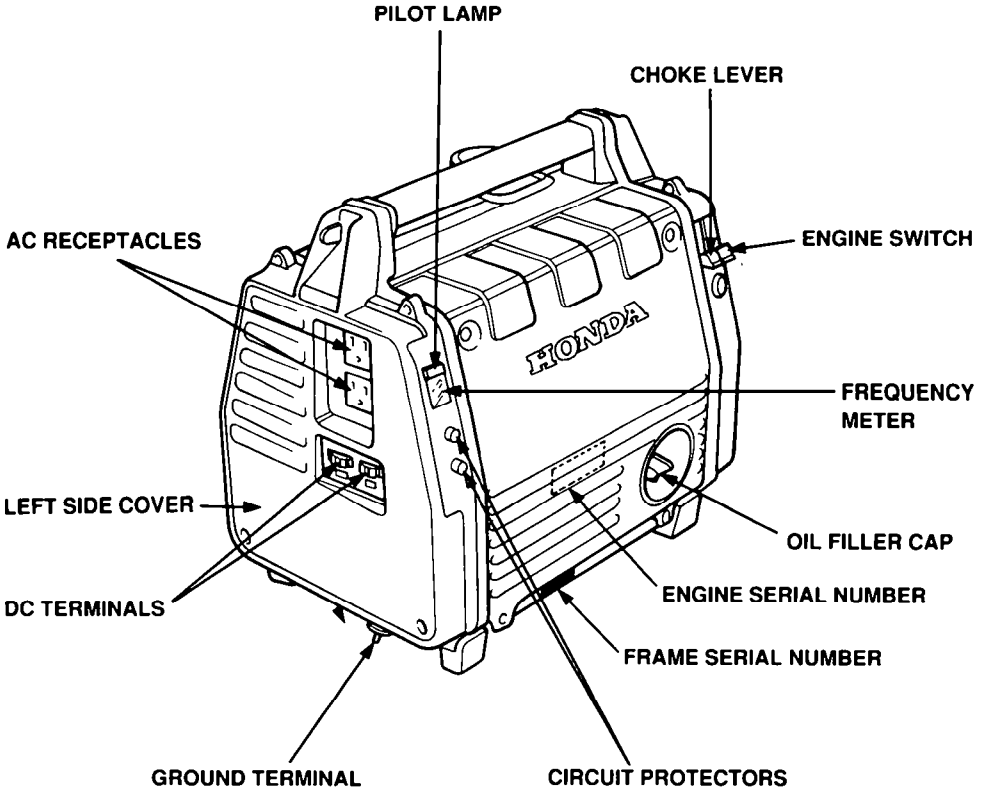

- Record the engine and frame serial numbers for your future reference. Refer to these serial numbers when ordering parts, and when making technical or warranty inquiries (see page 39)

Frame serial number: _____

Engine serial number: _____

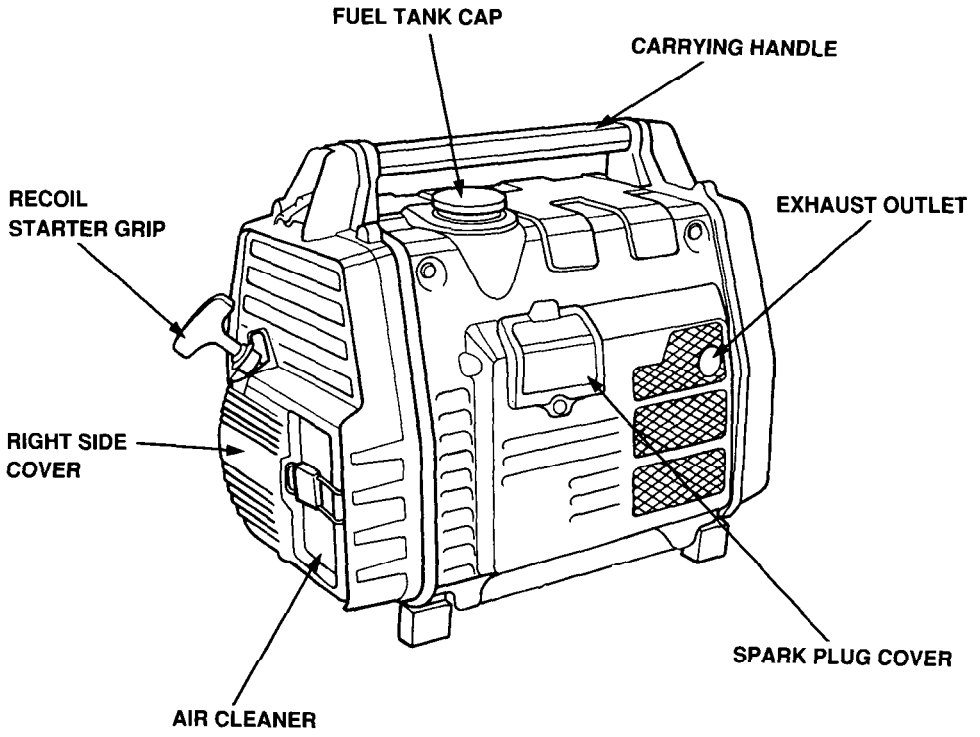

CONTROLS

Engine Switch

To start and stop the engine.

Switch position:

OFF: To stop the engine.

ON: To run the engine.

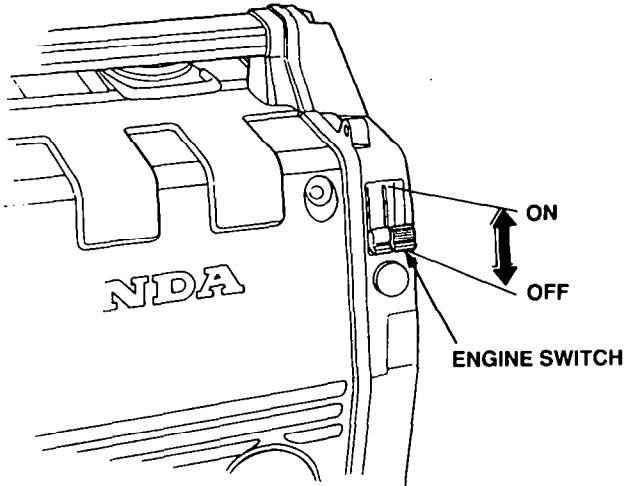

Recoil Starter

To start the engine, pull the starter grip lightly until resistance is felt, then pull briskly.

NOTICE Do not allow the starter to snap back against the engine. Return it gently to prevent damage to the starter.

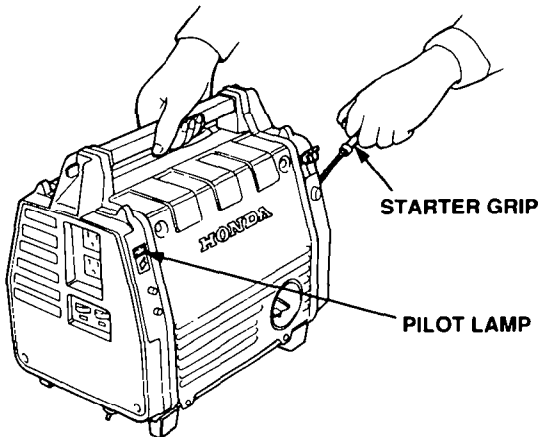

Choke Lever

The choke is used to provide an enriched fuel mixture when starting a cold engine.

It can be opened and closed by operating the choke lever manually. Move the lever to the CLOSED position to enrich the mixture.

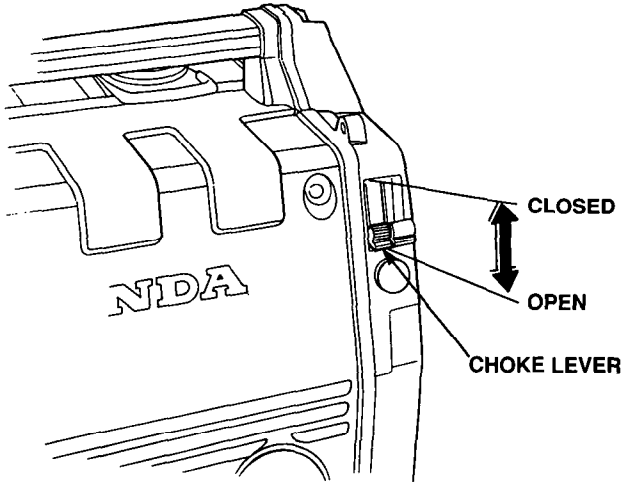

Pilot Lamp

The pilot lamp is illuminated when the generator is operating normally. It indicates that the generator is producing electrical power. If the pilot light is illuminated, the frequency meter should be displaying 60Hz.

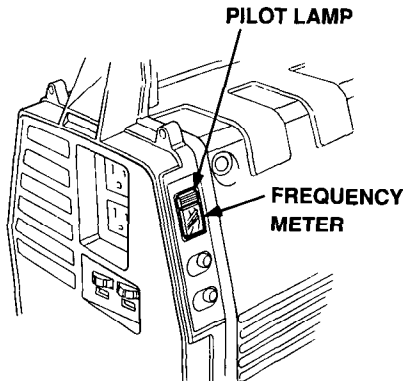

Ground Terminal

The generator ground terminal is connected to the frame of the generator, the metal non-current carrying parts of the generator, and the ground terminals of each receptacle.

Before using the ground terminal, consult a qualified electrician, electrical inspector or local agency having jurisdiction for local codes or ordinances that apply to the intended use of the generator.

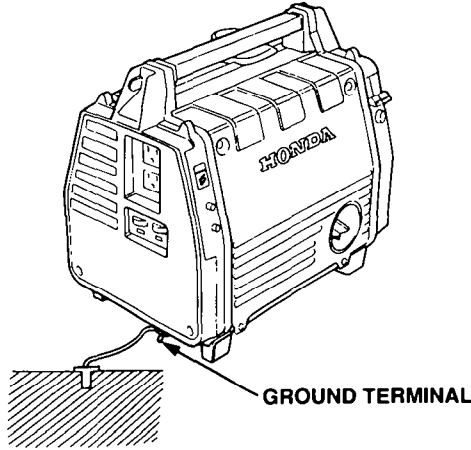

Oil Alert System

The Oil Alert system is designed to prevent engine damage caused by an insufficient amount of oil in the crankcase. Before the oil level in the crankcase can fall below a safe limit, the Oil Alert system will automatically stop the engine (the engine switch will remain in the ON position). If the engine stops and will not restart, check the engine oil level (p.20) before troubleshooting in other areas.

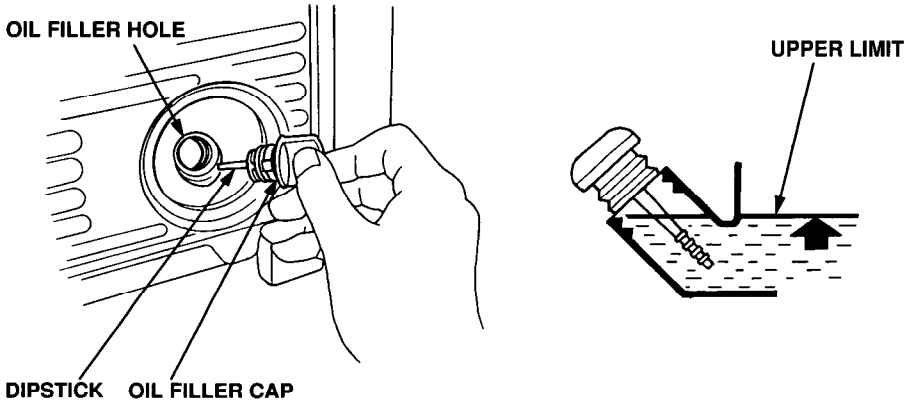

AC Circuit Protector

The AC circuit protector automatically shuts off the AC receptacle circuit when the generator is overloaded, when there is a problem with the electrical load; or the connections between the electrical load and the generator are improper.

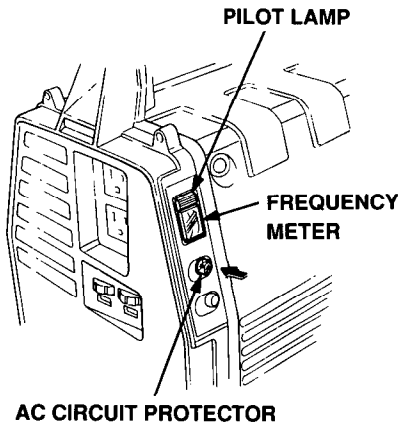

DC Terminals

The DC terminals may ONLY be used for charging 12 volt automotive type batteries.

The terminals are colored red to identify the positive (+) terminal and black to identify the negative (-) terminal. The battery must be connected to the generator DC terminals with the proper polarity (battery positive to generator red terminal and battery negative to the generator black terminal).

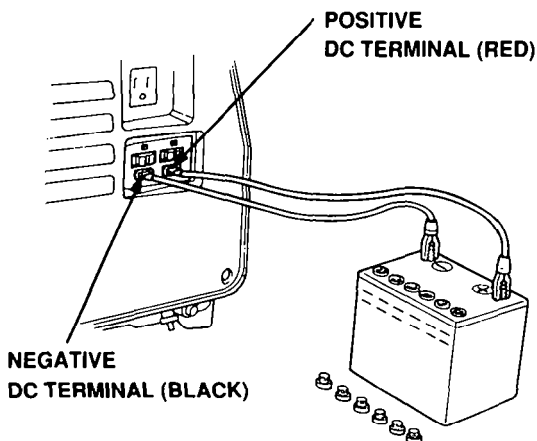

DC Circuit Protector

The DC circuit protector automatically shuts off the DC battery charging circuit when the generator is overloaded, when there is a problem with the battery; or the connections between the battery and the generator are improper.

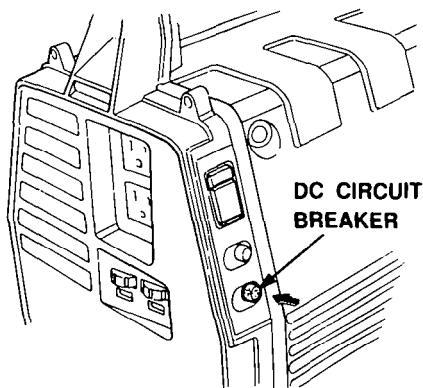

Connections to a Building's Electrical System

Connections for standby power to a building's electrical system must be made by a qualified electrician. The connection must isolate the generator power from utility power, and must comply with all applicable laws and electrical codes.

⚠ WARNING Improper connections to a building's electrical system can allow electrical current from the generator to backfeed into the utility lines. Such backfeed may electrocute utility company workers or others who contact the lines during a power outage. Consult the utility company or a qualified electrician.

NOTICE Improper connections to a building's electrical system can allow electrical current from the utility company to backfeed into the generator. When utility power is restored, the generator may explode, burn, or cause fires in the building's electrical system.

Ground System

Honda portable generators have a system ground that connects generator frame components to the ground terminals in the AC output receptacles. The system ground is not connected to the AC neutral wire. If the generator is tested by a receptacle tester, it will not show the same ground circuit condition as for a home receptacle.

Special Requirements

There may be Federal or State Occupational Safety and Health Administration (OSHA) regulations, local codes, or ordinances that apply to the intended use of the generator. Please consult a qualified electrician, electrical inspector, or the local agency having jurisdiction.

- In some areas, generators are required to be registered with local utility companies.
- If the generator is used at a construction site, there may be additional regulations which must be observed.

AC Operation

1. Start the engine (refer to page 23) and make sure the pilot lamp comes on.
If not, the filament may be burnt out.
2. Plug in the appliance.

NOTICE Substantial overloading will switch off the circuit protector. Marginal overloading may not switch off the circuit protector, but it will shorten the service life of the generator.

Be sure that all appliances are in good working order before connecting them to the generator. If an appliance begins to operate abnormally, becomes sluggish, or stops suddenly, turn off the generator engine switch immediately. Then disconnect the appliance and examine it for signs of malfunction.

NOTE: If an overloaded circuit trips the AC circuit protector, reduce the electrical load on the circuit, and wait a few minutes before resuming operation.

The green indicator inside the circuit protector button will pop out to show that the circuit protector has switched off.

Push the button in to reset the circuit protector.

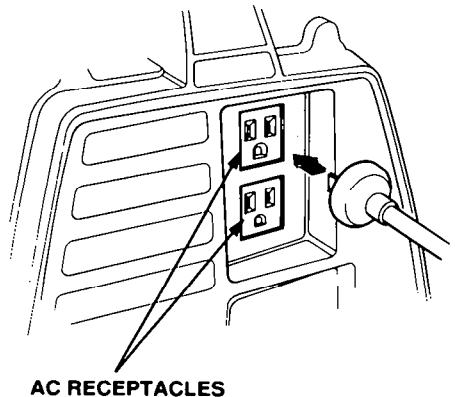
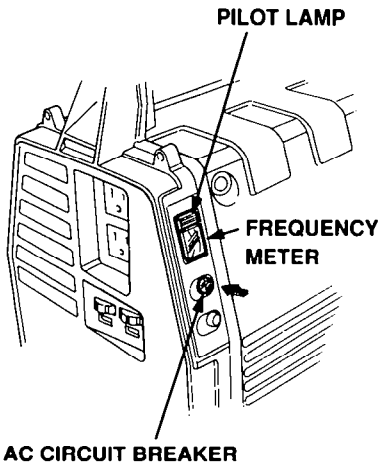

DC Operation

The DC terminals may ONLY be used for charging 12 volt automotive-type batteries.

Connecting the battery cables:

1. Before connecting charging cables to a battery that is installed in a vehicle, disconnect the vehicle's ground cable from the battery.

▲ WARNING The battery gives off explosive gases; keep sparks, flames and cigarettes away. Provide adequate ventilation when charging or using batteries.

2. Connect the positive (+) battery cable to the battery positive (+) terminal.
3. Connect the other end of the positive (+) battery cable to the generator positive (+) terminal.

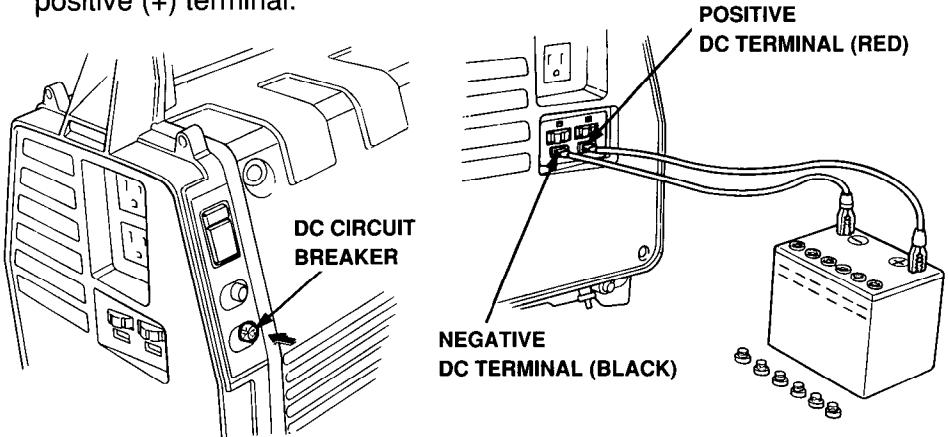

4. Connect the negative (-) battery cable to the battery negative (-) terminal.
5. Connect the other end of the negative (-) battery cable to the generator negative (-) terminal.
6. Start the generator.

NOTICE Do not start the vehicle while the battery charging cables are connected and the generator is running. The vehicle or the generator may be damaged.

An overloaded DC circuit, excessive current draw by the battery, or a wiring problem will trip the DC circuit protector (PUSH button extends out). If this happens, wait a few minutes before pushing in the circuit protector to resume operation. If the circuit protector continues to go OFF, discontinue charging and see your authorized Honda generator dealer.

Disconnecting the battery cables:

1. Stop the engine.
2. Disconnect the negative (-) battery cable from the generator negative (-) terminal.
3. Disconnect the other end of the negative (-) battery cable from the battery negative (-) terminal.
4. Disconnect the positive (+) battery cable from the generator positive (+) terminal.
5. Disconnect the other end of the positive (+) battery cable to the battery positive (+) terminal.
6. Connect the vehicle ground cable to the battery negative (-) terminal.

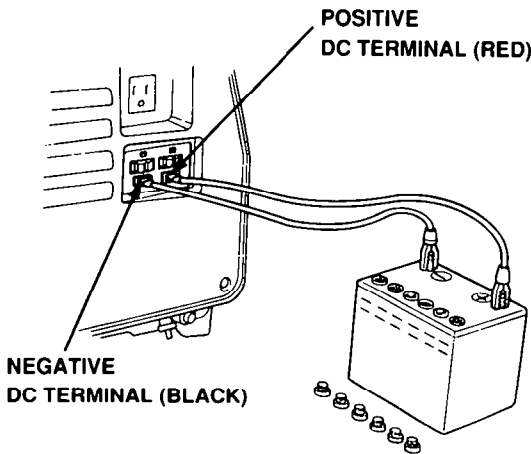

High Altitude Operation

At high altitude, the standard carburetor air-fuel mixture will be excessively rich. Performance will decrease, and fuel consumption will increase.

High altitude performance can be improved by installing a smaller diameter main fuel jet in the carburetor and readjusting the pilot screw. If you always operate the engine at altitudes higher than 6,000 feet above sea level, have an authorized Honda generator dealer perform this carburetor modification.

Even with suitable carburetor jetting, engine horsepower will decrease approximately 3.5% for each 1,000 foot increase in altitude. The effect of altitude on horsepower will be greater than this if no carburetor modification is made.

NOTICE If a generator jetted for high altitude is used at a lower altitude the lean air fuel mixture will reduce performance and may overheat and seriously damage the engine.

PRE-OPERATION CHECK

Engine Oil

NOTICE Engine oil is a major factor affecting engine performance and service life. Non-detergent and 2-stroke engine oils will damage the engine and are not recommended.

Check the oil level BEFORE EACH USE with the generator on a level surface with the engine stopped.

Use Honda 4-stroke oil, or an equivalent high detergent, premium quality motor oil certified to meet or exceed U.S. automobile manufacturer's requirements for Service Classification SG, SF/CC, CD.

Motor oils classified SG, SF/CC, CD will show this designation on the container.

SAE 10W-30 is recommended for general, all-temperature use. Other viscosities shown in the chart may be used when the average temperature in your area is within the indicated range.

1. Remove the oil filler cap and wipe the dipstick clean.
2. Check the oil level by inserting the dipstick into the filler neck without screwing it in.
3. If the oil level is low, fill to the top of the oil filler neck with the recommended oil.

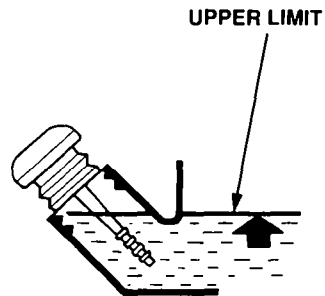
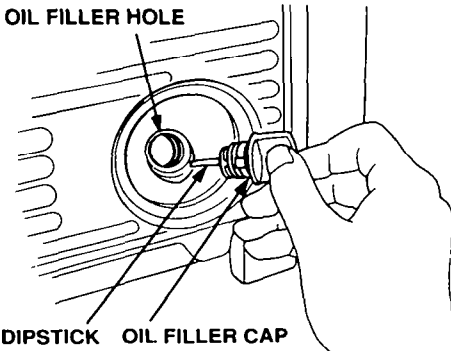
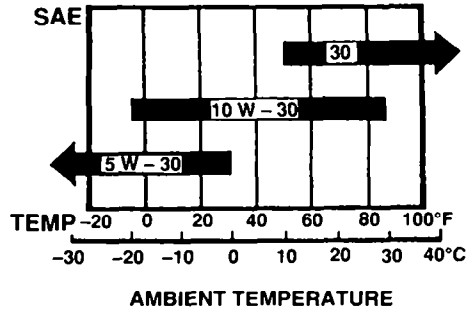

Fuel Recommendation

1. Check the fuel level gauge.
2. Refill the tank if the fuel level is low. Do not fill above the shoulder of the fuel strainer.

▲ WARNING

- Gasoline is extremely flammable and is explosive under certain conditions.
- Refuel in a well-ventilated area with the engine stopped. Do not smoke or allow flames or sparks in the area where the engine is refueled or where gasoline is stored.
- Do not overfill the fuel tank (there should be no fuel in the filler neck). After refueling, make sure the tank cap is closed properly and securely. Be careful not to spill fuel when refueling. Spilled fuel or fuel vapor may ignite. If any fuel is spilled, make sure the area is dry before starting the engine.
- Avoid repeated or prolonged contact with skin or breathing of vapor.
- **KEEP OUT OF REACH OF CHILDREN.**

Fuel tank capacity: 2.8 l (0.74 US gal, 0.62 Imp gal)

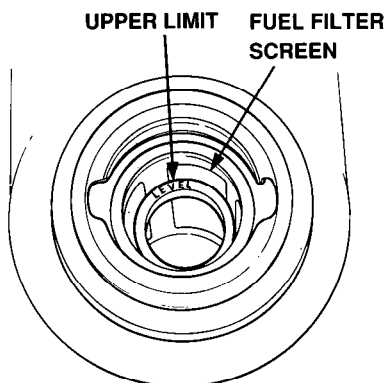
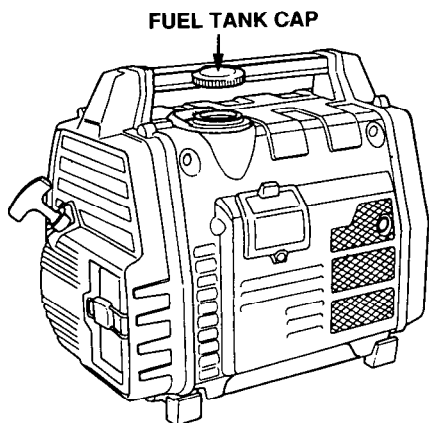

Use gasoline with a pump octane rating of 86 or higher

We recommend unleaded gasoline because it produces fewer engine and spark plug deposits and extends exhaust system life. Never use stale or contaminated gasoline or oil/gasoline mixture. Avoid getting dirt or water in the fuel tank.

Occasionally you may hear light “spark knock” or “pinging” (metallic rapping noise) while operating under heavy loads. This is no cause for concern.

If spark knock or pinging occurs at a steady engine speed, under normal load, change brands of gasoline. If spark knock or pinging persists, see an authorized Honda generator dealer.

NOTICE Running the engine with persistent spark knock or pinging can cause engine damage.

Running the engine with persistent spark knock or pinging is misuse, and the Distributor's Limited Warranty does not cover parts damaged by misuse.

Oxygenated Fuels

Some conventional gasolines are being blended with alcohol or an ether compound. These gasolines are collectively referred to as oxygenated fuels. To meet clean air standards, some areas of the United States and Canada use oxygenated fuels to help reduce emissions.

If you use an oxygenated fuel, be sure it is unleaded and meets the minimum octane rating requirement.

Before using an oxygenated fuel, try to confirm the fuel's contents. Some states/provinces require this information to be posted on the pump.

The following are the EPA approved percentages of oxygenates:

ETHANOL — (ethyl or grain alcohol) 10% by Volume

You may use gasoline containing up to 10% ethanol by volume. Gasoline containing ethanol may be marketed under the name "Gasohol".

MTBE — (methyl tertiary butyl ether) 15% by Volume

You may use gasoline containing up to 15% MTBE by volume.

METHANOL — (methyl or wood alcohol) 5% by Volume

You may use gasoline containing up to 5% methanol by volume as long as it also contains cosolvents and corrosion inhibitors to protect the fuel system. Gasoline containing more than 5% methanol by volume may cause starting and/or performance problems. It may also damage metal, rubber, and plastic parts of your fuel system.

If you notice any undesirable operating symptoms, try another service station or switch to another brand of gasoline.

Fuel system damage or performance problems resulting from the use of an oxygenated fuel containing more than the percentages of oxygenates mentioned above are not covered under warranty.

STARTING/STOPPING THE ENGINE

Starting the engine

1. The generator may be hard to start if a load is connected.
2. Move the choke lever to the CLOSE position.
3. Move the engine switch to the ON position.
4. Pull the starter grip until compression is felt, then pull briskly.

NOTICE Do not allow the starter grip to snap back. Return it slowly by hand.

5. Move the choke lever to the OPEN position as the engine warms up.

Stopping the engine

In an emergency:

- To stop the engine in an emergency, move the engine switch to the OFF position.

In normal use:

1. Turn off any AC electrical appliance, and disconnect DC battery charging cables.
2. Move the engine switch to the OFF position.

MAINTENANCE

Periodic maintenance and adjustment is necessary to keep the generator in good operating condition. Perform the service and inspection at the intervals shown in the Maintenance Schedule below.

⚠ WARNING Exhaust gas contains poisonous carbon monoxide. Shut off the engine before performing any maintenance. If the engine must be run, make sure the area is well ventilated.

NOTICE Use only genuine HONDA parts or their equivalent for maintenance or repair. Replacement parts which are not of equivalent quality may damage the generator.

MAINTENANCE SCHEDULE

REGULAR SERVICE PERIOD		Each use	First month or 20 Hrs. (3)	Every 3 months or 50 Hrs. (3)	Every 6 months or 100 Hrs. (3)	Every year or 300 Hrs. (3)
ITEM	Performed at every indicated month or operating hour interval, whichever comes first.					
Engine oil	Check level	○				
	Change		○		○	
Air cleaner	Check	○				
	Clean			○ (1)		
Spark plug	Check-Clean				○	
Spark Arrester	Clean				○	
Valve clearance	Check-Adjust					○ (2)
Combustion chamber and Valves	Clean-Relap					○ (2)
Fuel tank and filter	Clean					○ (2)
Fuel line	Check (Replace if necessary)	Every 2 years (2)				

- (1) Service more frequently when used in dusty areas.
- (2) These items should be serviced by an authorized Honda generator dealer, unless the owner has the proper tools and is mechanically proficient. See the Honda Shop Manual.
- (3) For professional commercial use, log hours of operation to determine proper maintenance intervals.

Engine Oil Change

Drain the oil while the engine is warm to assure complete and rapid draining.

1. Remove the oil filler cap.
2. Turn the engine switch OFF and tilt the generator to drain the oil.
3. Refill with the recommended oil (see page 20 and check the oil level).

Oil capacity: 0.35 l (0.37 US qt, 0.31 Imp qt)

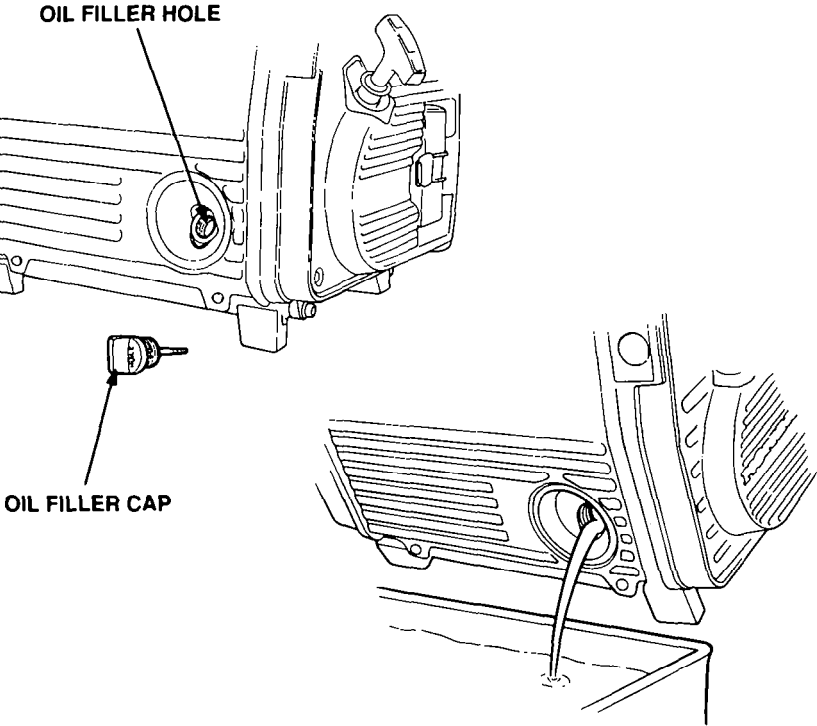

Please dispose of used motor oil and the oil containers in a manner that is compatible with the environment. We suggest you take it in a sealed container to your local service station or recycling center for reclamation. Do not throw it in the trash or pour it on the ground.

Air Cleaner Service

A dirty air cleaner will restrict air flow to the carburetor. To prevent carburetor malfunction, service the air cleaner regularly. Service more frequently when operating the generator in extremely dusty areas.

⚠ WARNING Using gasoline or flammable solvent to clean the filter element can cause a fire or explosion. Use only soapy water or nonflammable solvent.

NOTICE Never run the generator without the air cleaner. Rapid engine wear will result.

1. Unsnap the air cleaner case spring, and remove the cleaner case and air cleaner element.
2. Wash the element in a solution of household detergent and warm water, then rinse thoroughly, or wash in nonflammable or high flash point solvent. Allow the element to dry thoroughly.
3. Soak the element in clean engine oil and squeeze out the excess oil. The engine will smoke during initial startup if too much oil is left in the element.
4. Reinstall the air cleaner element and cleaner case.

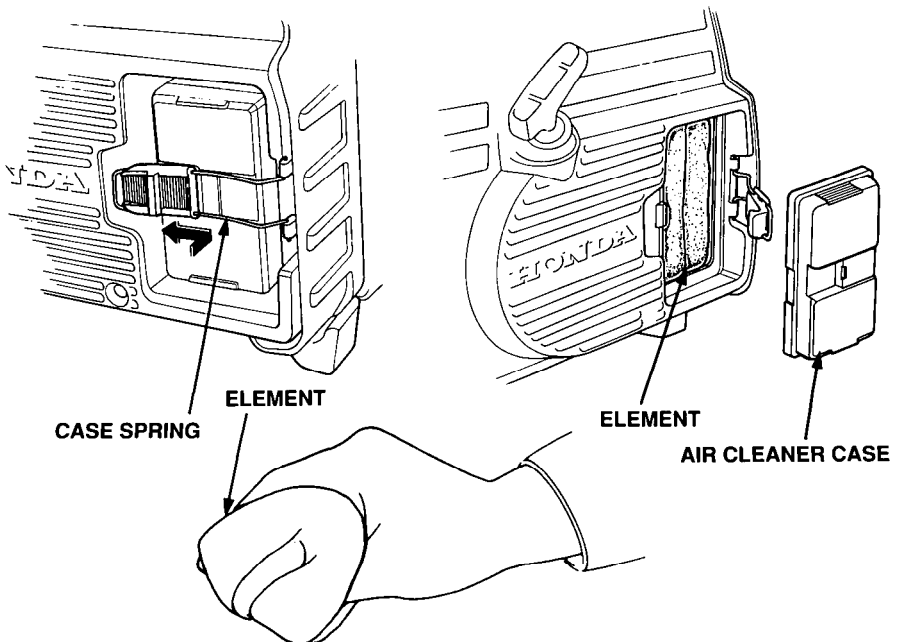

-
4. Visually inspect the spark plug. Discard it if the insulator is cracked or chipped. Clean the spark plug with a wire brush if it is to be reused.
 5. Measure the plug gap with a feeler gauge.
Correct as necessary by carefully bending the side electrode.

The gap should be: 0.6~0.7 mm (0.024~0.028 in)

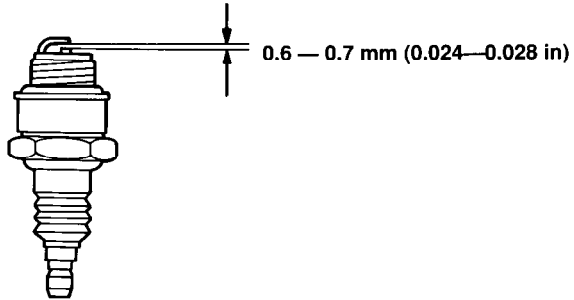

6. Check that the spark plug washer is in good condition, and thread the spark plug in by hand to prevent cross-threading.

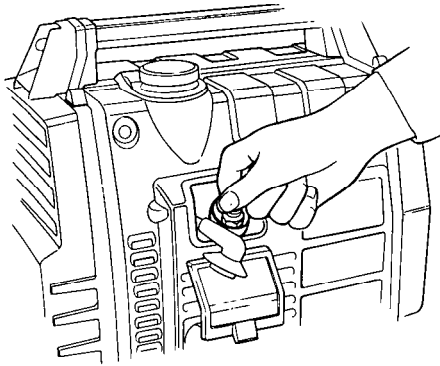

7. After the spark plug is seated, tighten with a spark plug wrench to compress the washer.

— If installing a new spark plug, tighten 1/2 turn after the spark plug seats to compress the washer. If reinstalling a used spark plug, tighten 1/8—1/4 turn after the spark plug seats to compress the washer.

NOTICE The spark plug must be securely tightened. An improperly tightened spark plug can become very hot and could damage the engine. Never use spark plugs which have an improper heat range. Use only the recommended spark plugs or equivalent.

Spark Arrester Maintenance

If the generator has been running, the muffler will be very hot. Allow to cool before proceeding.

NOTICE The spark arrester must be serviced every 100 hours to maintain its efficiency.

1. Remove the fuel tank cap.
2. Remove the four 5 mm pan-screws, and then remove the rear cover. Retighten the fuel tank cap.
3. Remove the two 6 mm bolts, and then remove the muffler protector.

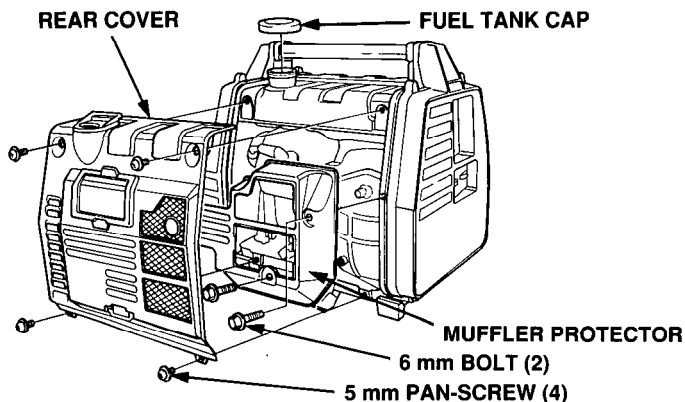

4. Remove the three 6 mm bolts that hold the muffler. Move the muffler to the right and up as far as possible. Carefully remove the spark arrester from the muffler.

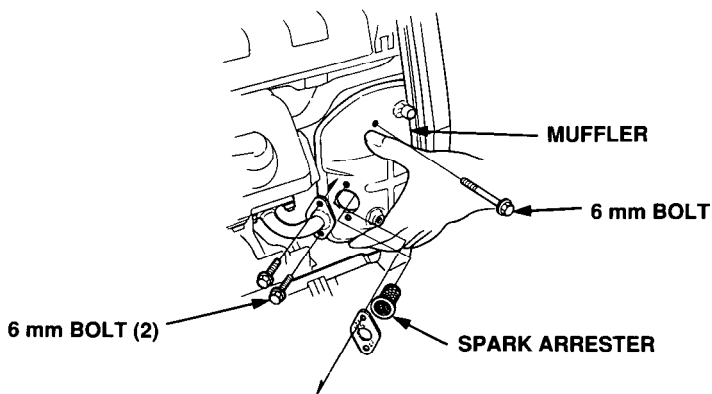

-
5. Check for carbon deposits around the exhaust port and the spark arrester. Use a brush to remove carbon deposits from the spark arrester screen. Inspect the spark arrester screen for holes or tears. Replace if necessary.

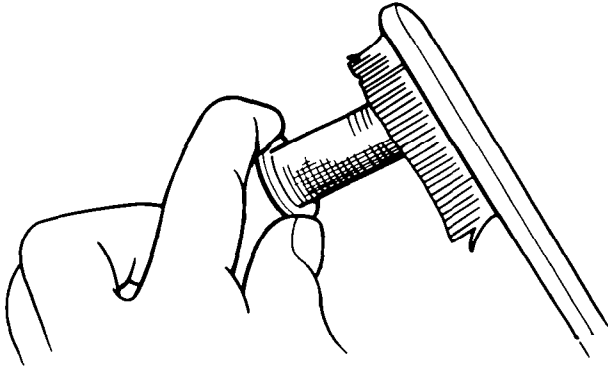

NOTE: The spark arrester must be free of breaks and holes. Replace, if necessary.

6. Install the spark arrester and the muffler in a reverse order. Check the exhaust pipe gasket and replace if damaged. Reinstall the muffler and the protector.

TRANSPORTING/STORAGE

When transporting the generator, turn engine switch and the fuel valve OFF. Keep the generator level to prevent fuel spillage. Fuel vapor or spilled fuel may ignite.

▲ CAUTION Contact with a hot engine or exhaust system can cause serious burns or fires. Let the engine cool before transporting or storing the generator.

Take care not to drop or strike the generator when transporting. Do not place heavy objects on the generator.

Before storing the unit for an extended period:

1. Be sure the storage area is free of excessive humidity and dust.
2. Service according to the table below:

STORAGE TIME	RECOMMENDED SERVICE PROCEDURE TO PREVENT HARD STARTING
Less than 1 month	No preparation required
1 to 2 months	Fill with fresh gasoline and add gasoline conditioner*.
2 months to 1 year	Fill with fresh gasoline and add gasoline conditioner*. Drain the carburetor float bowl (page 33).
1 year or more	Fill with fresh gasoline and add gasoline conditioner*. Drain the carburetor float bowl (page 33). Remove the spark plug. Put a tablespoon of engine oil into the cylinder. Turn the engine slowly with the pull rope to distribute the oil. Reinstall the spark plug. Change the engine oil (page 26). After removal from storage, drain the stored gasoline into a suitable container, and fill with fresh gasoline before starting.

* Use gasoline conditioners that are formulated to extend storage life. Contact your authorized Honda generator dealer for conditioner recommendations.

1. Drain the carburetor by loosening the drain screw. Drain the gasoline into a suitable container.

▲ WARNING Gasoline is extremely flammable and is explosive under certain conditions. Perform this task in a well ventilated area with the engine stopped. Do not smoke or allow flames or sparks in the area during this procedure.

2. Drain the fuel –
 - a. With the engine switch ON, remove the fuel filler cap.
 - b. Loosen the drain screw and drain the fuel into a suitable container. Retighten the screw.
 - c. Move the engine switch to OFF.

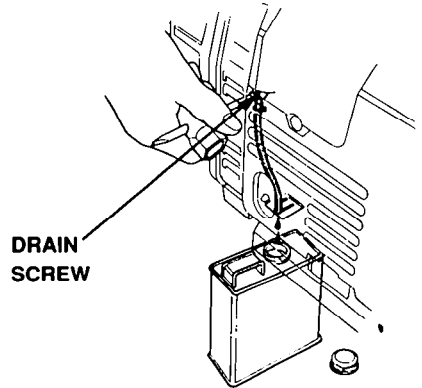

2. Change the engine oil (page 26).
3. Remove the spark plug, and pour about a tablespoon of clean engine oil into the cylinder. Crank the engines several revolutions to distribute the oil, then reinstall the spark plug.
4. Slowly pull the starter grip until resistance is felt. At this point, the piston is coming up on its compression stroke and both the intake and exhaust valves are closed. Storing the engine in this position will help to protect it from internal corrosion.

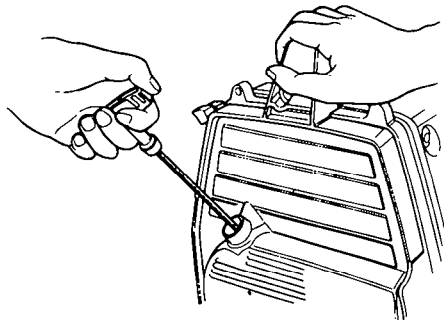

TROUBLESHOOTING

When the engine will not start:

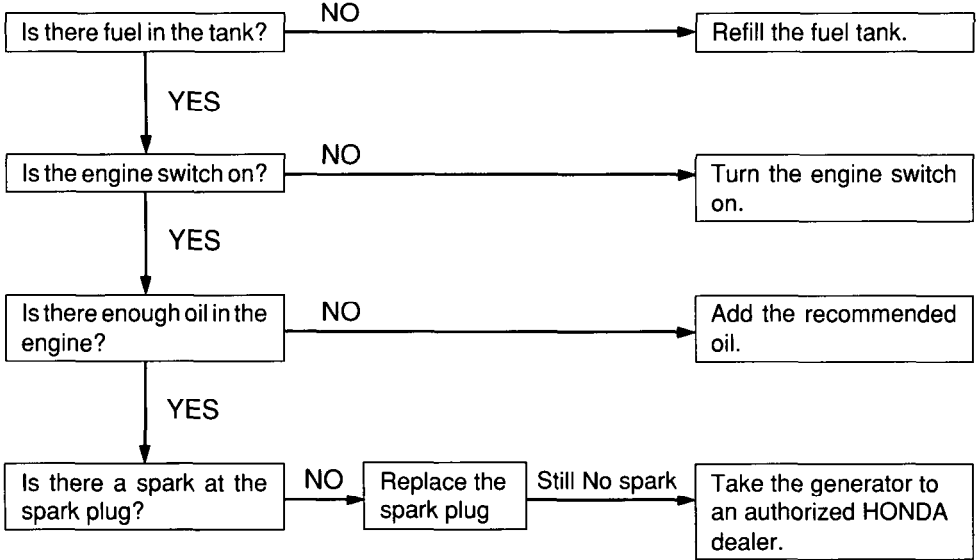

⚠ WARNING

Be sure there is no spilled fuel around the spark plug. Spilled fuel may ignite.

YES

Is fuel reaching the carburetor?

YES

If the engine still dose not start, take the generator to an authorized HONDA generator dealer.

To check:

- 1) Remove the rear cover and spark plug cap, and clean any dirt from around the spark plug.
- 2) Remove the spark plug and install the spark plug in the plug cap.
- 3) Set the plug side electrode on the cylinder head to ground.
- 4) Pull the recoil starter, sparks should jump across the gap.

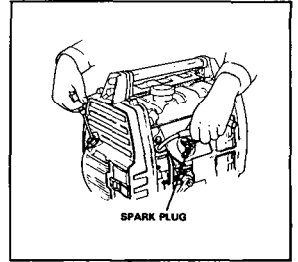

To check:

- 1) Turn off the engine switch and loosen the drain screw.
- 2) Fuel should flow from the drain when the engine switch is turned on.

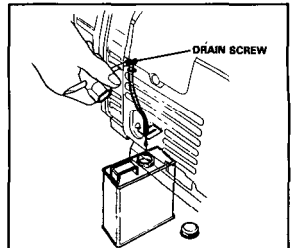

No electricity at the AC receptacles:

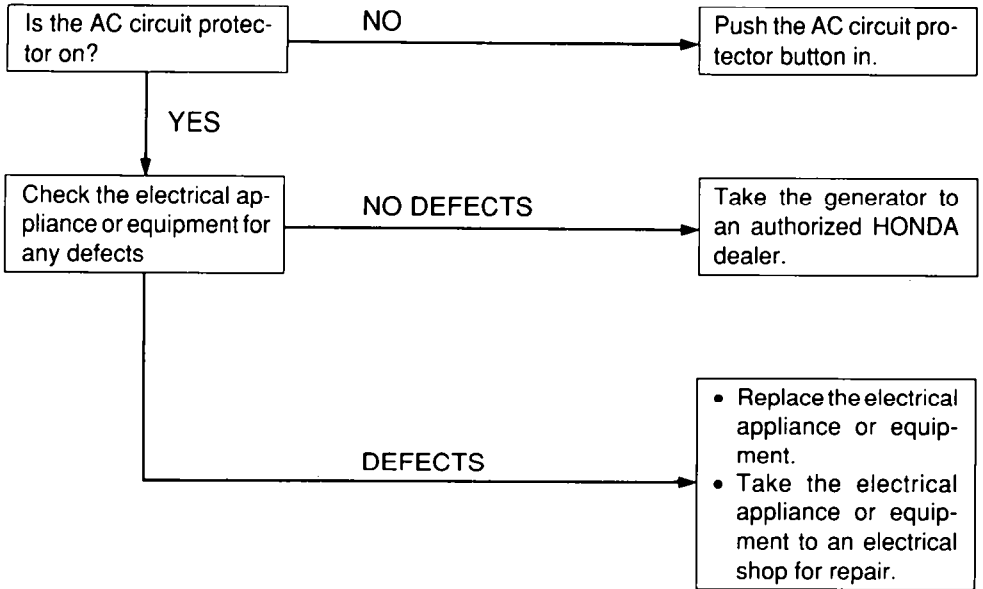

No electricity at the DC terminals

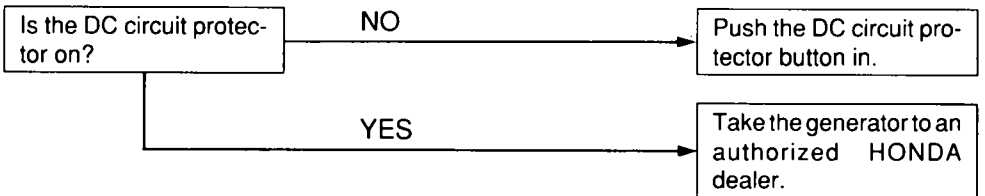

WIRING DIAGRAM

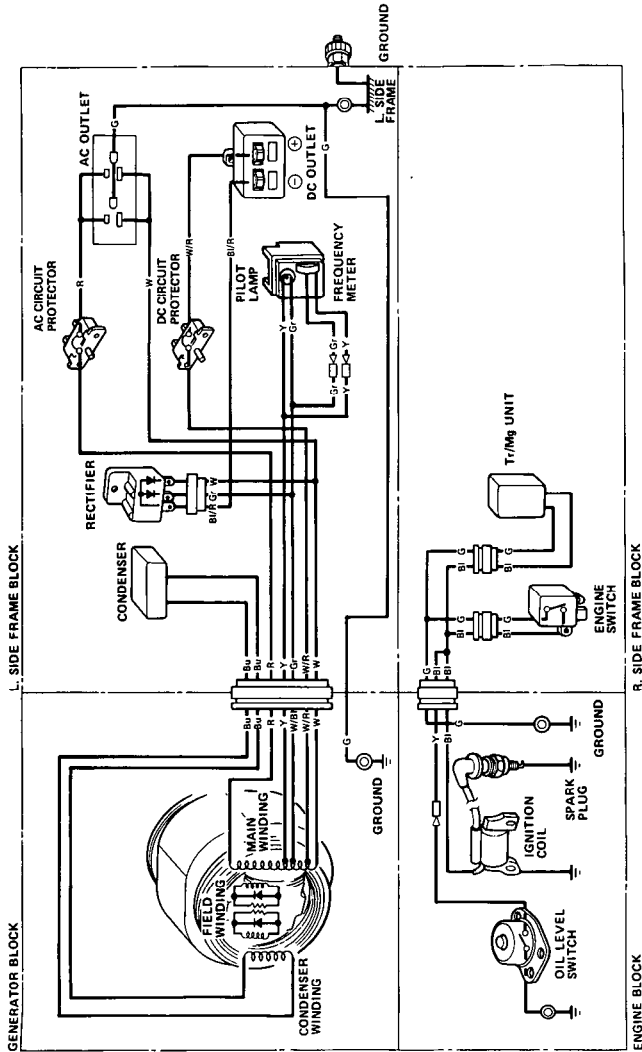

B _l	BLACK
B _r	BROWN
G	GREEN
G _r	GRAY
B _u	BLUE
L _b	LIGHT BLUE
L _g	LIGHT GREEN
O	ORANGE
P	PINK
R	RED
W	WHITE
Y	YELLOW

SPECIFICATIONS

Dimension

Power product description code	EA3
Length × Width × Height	410 × 270 × 375 mm (16.1 × 10.6 × 14.8 in)
Dry Weight	22 kg (48.5 lb)

Engine

Engine Type	4-stroke, side valve, 1 cylinder
Displacement [Bore × Stroke]	76 cc (4.65 cu in) [46 × 46 mm (1.81 × 1.81 in)]
Compression Ratio	6 : 1
Engine Speed	3,600 r.p.m.
Cooling System	Forced air cooling
Ignition System	Transistorized magneto
Oil Capacity	0.35 ℓ (0.37 US qt)
Fuel Tank Capacity	2.8 ℓ (0.74 US qt)
Spark Plug	BMR-4A (NGK), W14MR-U (NIPPONDENSO)

Generator

AC output	Rated Voltage	120 V
	Rated Frequency	60 Hz
	Rated Amperage	4.6 A
	Rated Output	550 VA
	Maximum Output	650 VA
DC output	Only for charging 12 V automotive batteries. Maximum charging output = 8.3 A	

NOTE: Specifications are subject to change without notice.

CUSTOMER SERVICE INFORMATION

Honda power equipment dealership personnel are trained professionals. They should be able to answer any question you may have. If you encounter a problem that your dealer does not solve to your satisfaction, please discuss it with the dealership's management. The Service Manager or General Manager can help. Almost all problems are solved in this way.

If you are dissatisfied with the decision made by the dealership's management, contact the Honda Power Equipment Customer Service Office. You can write to:

American Honda Motor Co., Inc.
Honda Power Equipment Division
Customer Service Office
4475 River Green Parkway
Duluth, Georgia 30136-2565

Or telephone: (404)497-6400

When you write or call, please give us this information:

- Model and serial number (see page 8)
- Name of dealer who sold the generator to you
- Name and address of dealer who services your generator
- Date of purchase
- Your name, address, and telephone number
- A detailed description of the problem

Current customer service contact information:

United States, Puerto Rico, and U.S. Virgin Islands:

Honda Power Equipment dealership personnel are trained professionals. They should be able to answer any question you may have. If you encounter a problem that your dealer does not solve to your satisfaction, please discuss it with the dealership's management. The Service Manager or General Manager can help. Almost all problems are solved in this way.

If you are dissatisfied with the decision made by the dealership's management, contact the Honda Power Equipment Customer Relations Office. You can write:

American Honda Motor Co., Inc.
Power Equipment Division
Customer Relations Office
4900 Marconi Drive
Alpharetta, GA 30005-8847

Or telephone: (770) 497-6400 M-F, 8:30 am - 7:00 pm EST

When you write or call, please provide the following information:

- Model and serial numbers
- Name of the dealer who sold the Honda power equipment to you
- Name and address of the dealer who services your equipment
- Date of purchase
- Your name, address, and telephone number
- A detailed description of the problem

INDEX

COMPONENT IDENTIFICATION	8
CONTROLS	10
AC Circuit Protector	13
Choke Lever	11
DC Circuit Protector	14
DC Terminals	14
Engine Switch	10
Ground Terminal	12
Oil Alert System	13
Pilot Lamp	11
Recoil Starter	10
CUSTOMER SERVICE INFORMATION	39
GENERATOR USE	15
AC Operation	16
Connecting the battery cables	17
DC Operation	17
Disconnecting the battery cables	17
High Altitude Operation	19
MAINTENANCE	25
Air Cleaner Service	27
Engine Oil Change	26
Maintenance Schedule	25
Spark Arrester Maintenance	31
Spark Plug Service	28

PRE-OPERATION CHECK	20
Engine Oil	20
Fuel Recommendation	21
SAFETY	4
Safety Information	6
Safety Label Locations	4
SPECIFICATIONS	38
STARTING/STOPPING THE ENGINE	24
TRANSPORTING/STORAGE	33
TROUBLESHOOTING	35
WIRING DIAGRAM	37

MEMO

MEMO

MEMO

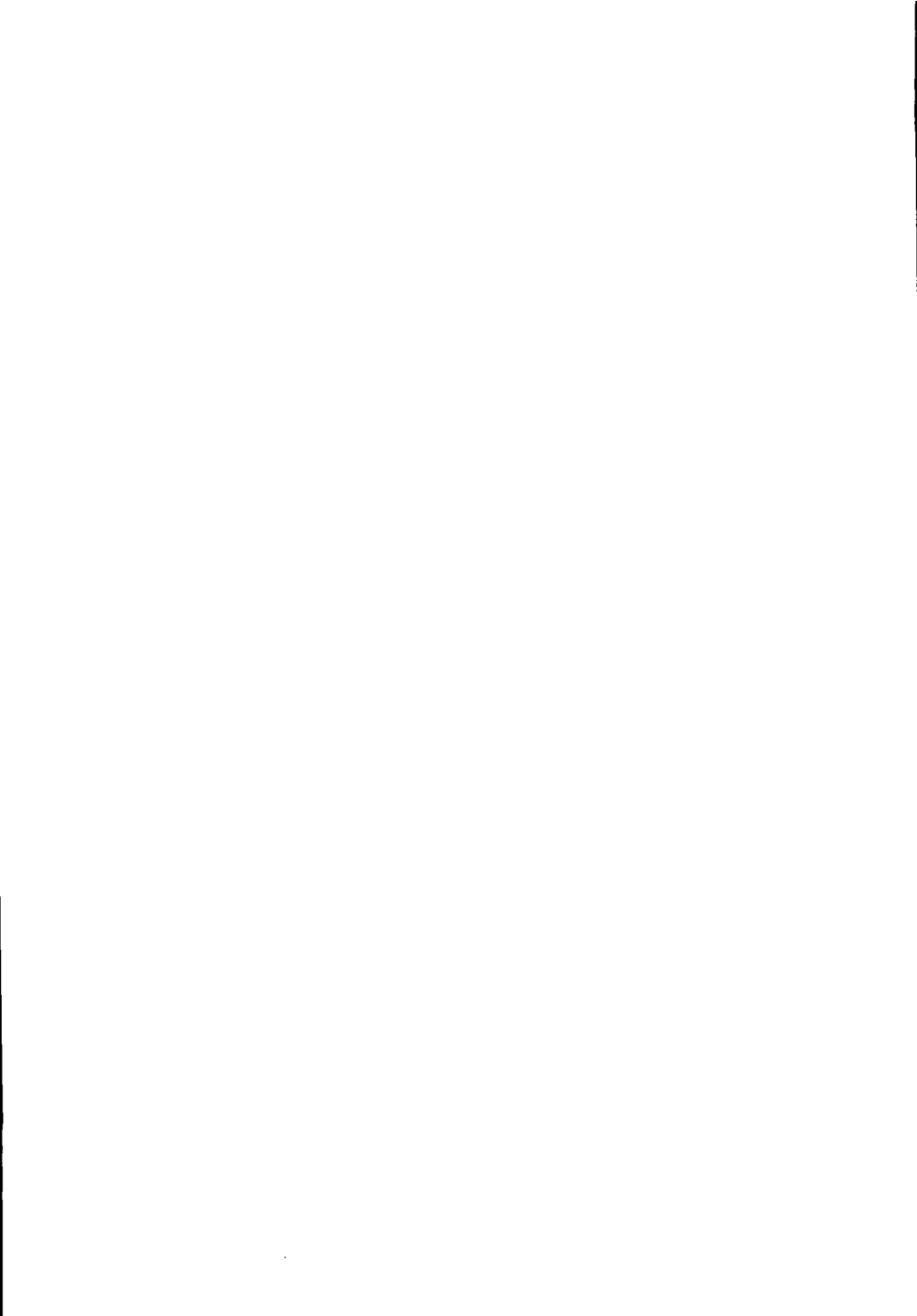

HONDA
HONDA MOTOR CO., LTD. TOKYO, JAPAN

31ZA8810
00X31-ZA8-8101

Ⓐ Ⓑ Ⓒ 5009512
PRINTED IN JAPAN